

## Standard Construction and Materials

**FRAME:** .125" thick (nominal) extruded aluminum.

**BLADE:** .125" thick (nominal) extruded aluminum.

**SCREEN:** 19/16 Mesh, .011" dia. aluminum wire, insect screen.

**FINISH:** Clear anodized finish is standard.

## Options

Finish - Baked Enamel, Kynar, Anodize

## Notes

1. ½" nominal deduction will be made to the opening size given unless otherwise stated.
2. Many stock sizes are available for immediate shipment. Brick vents are also available in practically any width or height.

Body Size	Minimum Opening Size	Free Area (Sq. In.)
8½" x 2¾"	8½" x 2⅝"	4.18
8½" x 4¾"	8½" x 5"	11.52
8½" x 7¾"	8½" x 8"	19.58
16½" x 2¾"	17" x 2⅝"	8.64
16½" x 4¾"	17" x 5"	28.22
16½" x 7¾"	17" x 8"	40.32
12" x 2¾"	12½" x 2⅝"	6.34
12" x 4¾"	12½" x 5"	17.28
24" x 4¾"	24½" x 5"	39.02
24" x 7¾"	24½" x 8"	58.75

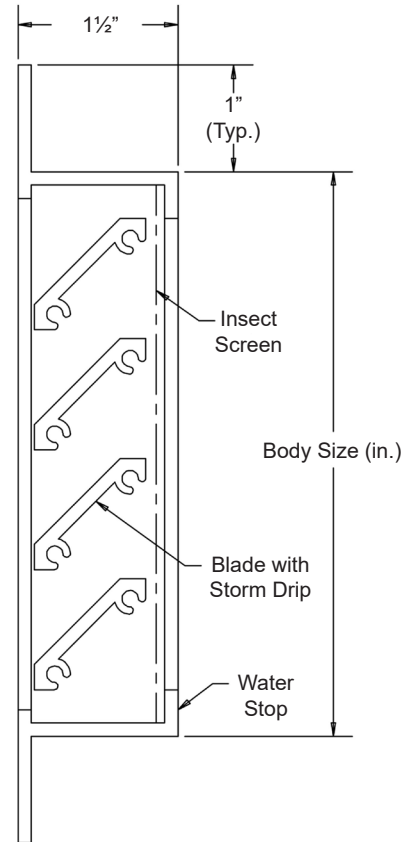

For custom size Brick Vents, contact customer service for details.

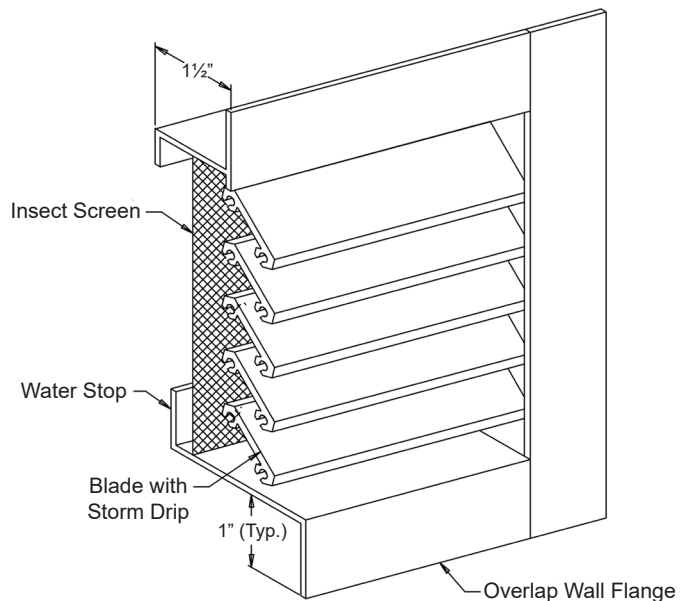

For handwritten orders, use the schedule block on page 2.

In the interest of product development, Cesco Products reserves the right to make changes without notice.

Item	Qty	Opening Size		Finish	Tagging	Net Each	Total
		Width ("A")	Height ("B")				